

DuraVane oil-free rotary vane compressors are heavy-duty compact motor-mounted units, extremely reliable for many industrial applications. Efficient cooling is insured by a powerful centrifugal fan.



Performance characteristics

Displacement:	2CFM
Maximum Pressure:	11.6psig
Motor:	0.2HP/60HzTEFC
Voltage:	110V/1phase
Speed:	3400RPM
Noise level(at 3ft):	62dBA
Weight:	11Lbs
Inlet conn.:	1/8"NPT
Discharge conn.:	1/8"NPT

- Fewer vanes than other oil-free rotary vane compressors.
- High-tech, self-lubricating graphite composite vane material.
- Longer vane life and less vane replacement.
- Heavy-duty construction.
- Compact design, small footprint.
- Low noise level.
- Air-cooled design.
- Direct drive.
- Simple to install.

RCD002

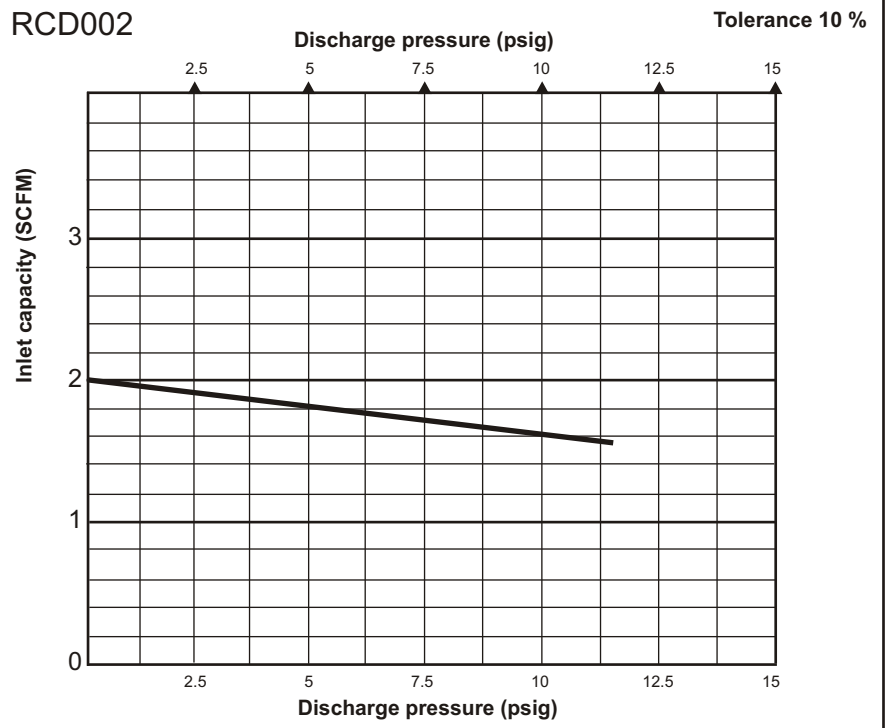

RCD002

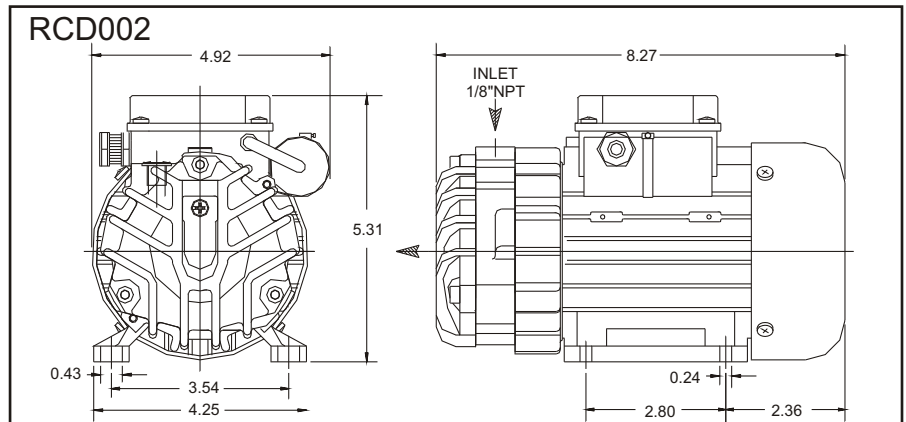

Information contained in this document is for reference only. Subject to change without notice.