

Presenting the **TITAN** SERIES  
*two-stage liquidring  
vacuum pump.*

Why should you consider this vacuum pump for your application?

- ◆ Designed for heavy duty applications.
- ◆ Optional monoblock adaptor available, which utilizes NEMA C-face motors.
- ◆ Manufactured to ISO 9001 standards
- ◆ Low operating noise level.
- ◆ Heavy duty bearings mounted external to the pumping chamber.
- ◆ Features single face mechanical seals as standard.
- ◆ Virtually no maintenance is required.
- ◆ Capable of handling saturated gas mixtures.
- ◆ Capable of handling small amounts of liquids.
- ◆ Only one moving part.
- ◆ Can operate using various seal-fluids.

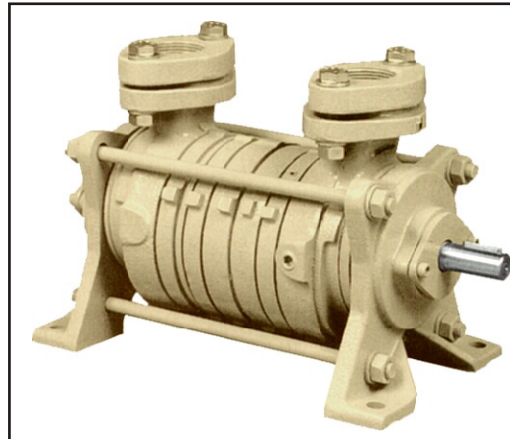

**Performance characteristics**  
 Nominal capacity: 15CFM  
 Motor: 50Hz/1.5HP/1.1kW  
 60Hz/2HP/1.5kW  
 Speed(RPM): 50Hz/2900  
 60Hz/3500  
 Max.vacuum: 28.7"Hg/30Torr  
 Weight (bare-shaft): 50Lbs/23kg  
 Max. gas inlet temp: 212°F/100°C  
 Max.noise level(at 3ft): 66dBA  
*Performance based on dry air, seal-water temperature 60°F and atmospheric pressure of 29.92"Hg.*

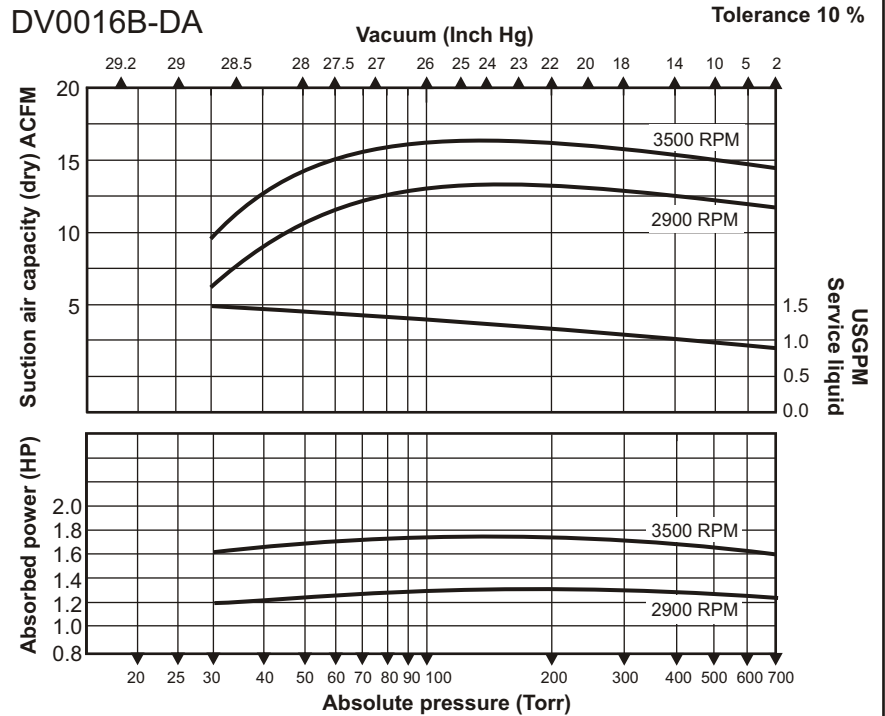

Materials of construction/Seal code				
Mat.code	1	2	3	4
Casing	NA	cast iron	NA	NA
Portplate	NA	cast iron	NA	NA
Impeller	NA	bronze	NA	NA
Shaft	NA	420 SS	NA	NA
Seal code	NA	A*	NA	NA

A= standard mechanical seal with Viton elastomer  
 B= standard mechanical seal with Teflon elastomer  
 \* = other seal materials available upon request.

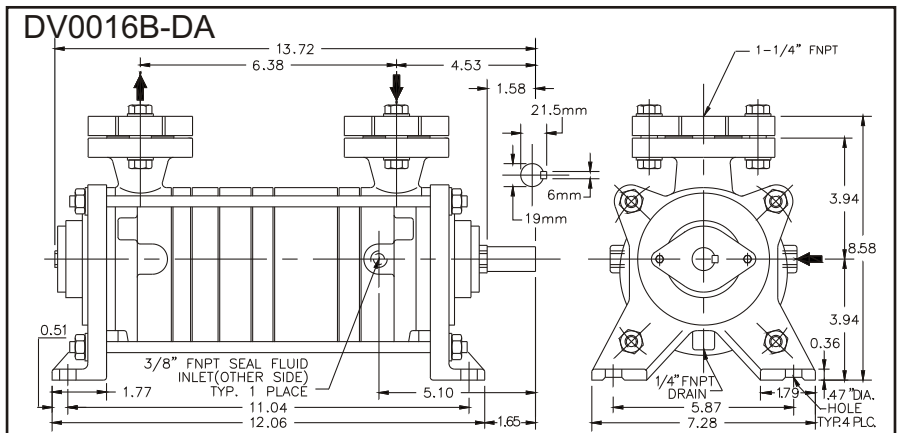

Dimensions (inches) not binding. Subject to change without notice. Companion flanges included.