

**DuraVane** lubricated rotary vane pumps are single-stage pumps with an integrated closed loop oil recirculation system.

- Heavy duty construction.
- Compact design, small footprint.
- High-tech vane material provides long vane life.
- Gas ballast valve is standard.
- Low noise level.
- Low maintenance.
- Air-cooled design.
- High efficiency multi-stage exhaust filter removes 99.9% of exhaust smoke.
- Direct drive.
- Simple to install.

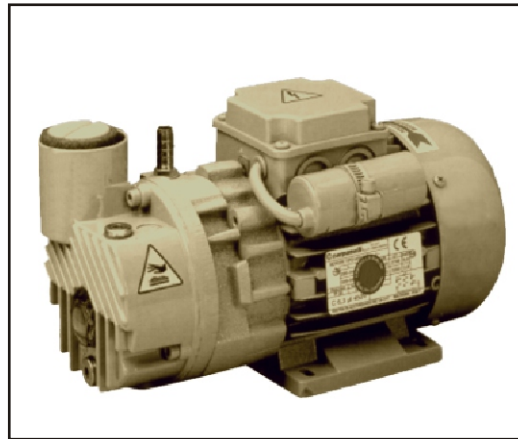

**Performance characteristics**

Displacement:	2CFM
Final pressure:	1.5Torr
Motor:	0.2HP-50/60HzTEFC
Voltage:	110V/120V-1phase
Speed:	2900/3400RPM
Noise level(at 3ft):	60dBA
Oil reservoir cap.:	0.06qt
Oil type:	Duratex 32
Weight:	12Lbs
Inlet conn.:	3/8" hose
Discharge conn.:	3/8" hose

RVL002H

Based on 29.92 inch Hg (1013 mbar) barometric pressure.  
Inlet temperature 70° deg. F.

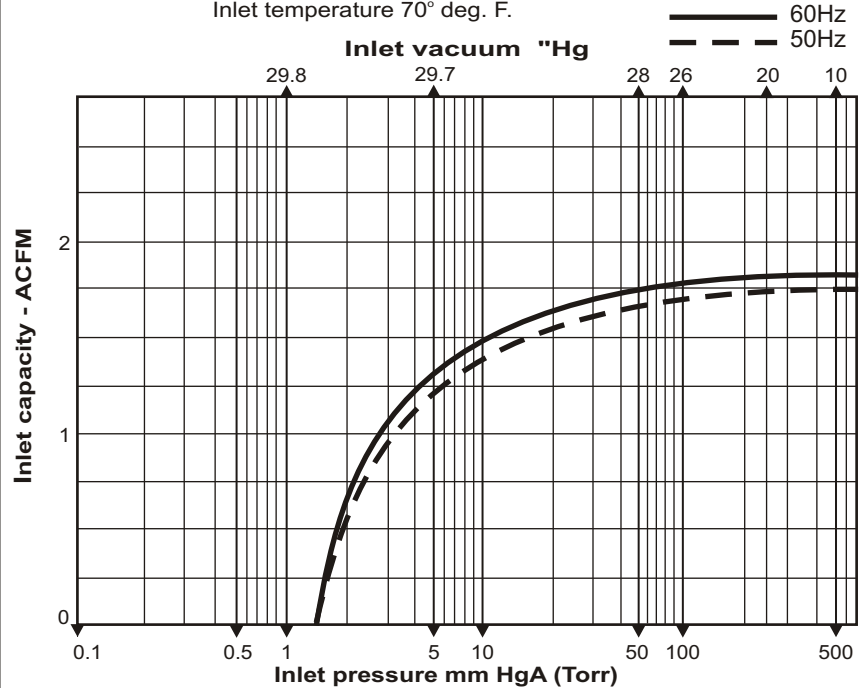

RVL002H

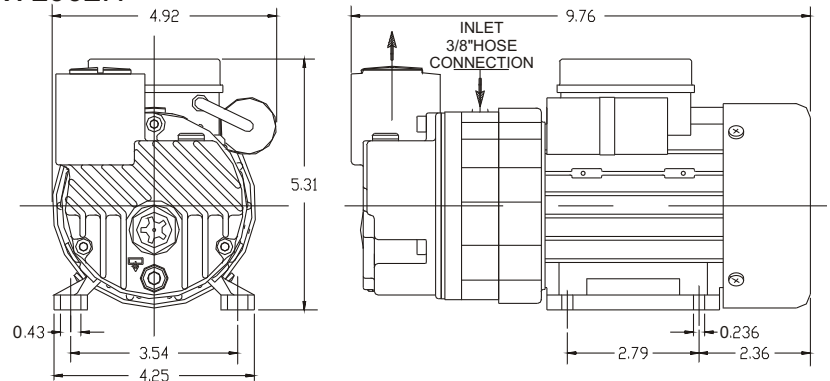

Information contained in this document is for reference only. Subject to change without notice.