

DuraVane
Lubricated rotary vane pump
RVL700HH/LH

DuraVane lubricated rotary vane pumps are single-stage pumps with an integrated closed loop oil recirculation system.

- Heavy duty construction.
- Compact design, small footprint.
- High-tech vane material provides long vane life.
- Low noise level.
- Low maintenance.
- Air-cooled design.
- Internally mounted inlet check valve.
- High efficiency multi-stage exhaust filter removes 99.9% of exhaust smoke.
- Direct drive.
- Simple to install.

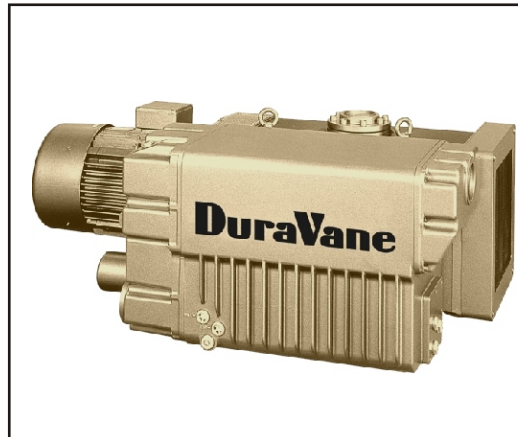

Performance characteristics

Displacement:	710CFM
Final pressure:	0.5/15Torr
Motor 50Hz:	30HP/22kW
Motor 60Hz:	40HP/30kW
Voltage:	230/380/460V/3phase
Speed 50Hz:	980RPM
Speed 60Hz:	1200RPM
Noise level(at 3ft):	81dBA
Oil reservoir cap.:	18qt
Oil type:	Duratex 100
Weight:	2100Lbs
Inlet conn.:	4"NPT
Discharge conn.:	3"NPT

*For continuous operation from 300-0.5Torr select RVL700HH.
For continuous operation from 500-15Torr select RVL700LH*

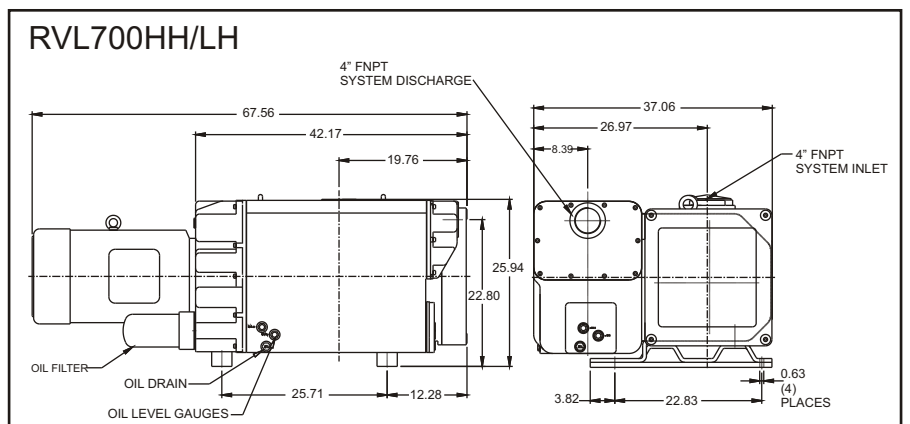
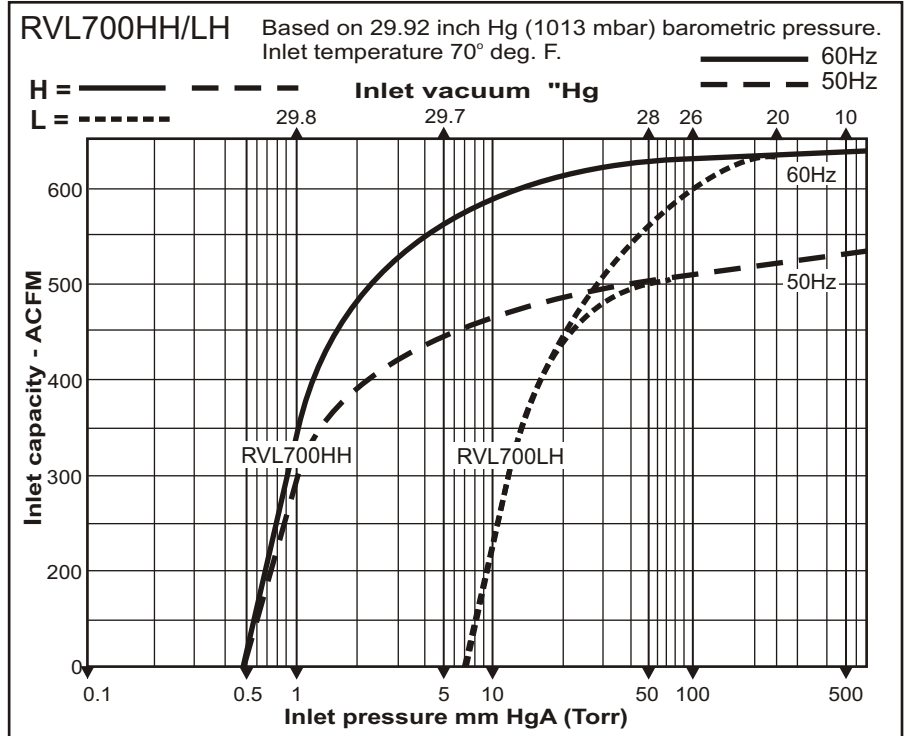

Information contained in this document is for reference only. Subject to change without notice.