



DEKKER
VACUUM TECHNOLOGIES, INC.

Installation
Operation
&
Maintenance
Manual

DuraVane^{HV}

High Vacuum Lubricated Rotary Vane Pumps

DuraVane^{HV}

HIGH VACUUM LUBRICATED ROTARY VANE PUMPS

TABLE OF CONTENTS

CUSTOMER SERVICE	5
CONTACT INFORMATION	5
ORDER INFORMATION	5
INTRODUCTION	6
SAFETY	6
THEORY OF OPERATION	7
STORAGE	7
INITIAL FREIGHT RECEIPT AND INSPECTION	7
INSTALLATION	7
OVERVIEW	7
UNPACKING	7
LIFTING	7
LOCATION	8
MOUNTING	8
VENTILATION	8
ELECTRICAL PREPARATION	9
PIPE CONNECTION AND SIZING	9
INLET PIPING	9
START-UP PROCEDURES	11
SHUT DOWN PROCEDURES	12
MAINTENANCE	12
PUMP DETAIL	12
GAS BALLAST	12
PUMP OIL LEVEL (CHECK DAILY)	12
MAINTENANCE SCHEDULE	13
FIRST 8 HOURS OF OPERATION	13
DAILY	13
500 HOURS OF OPERATION	13
1000 HOURS OF OPERATION	13
50,000 HOURS OF OPERATION	13
TROUBLESHOOTING	13

START-STOP PROBLEMS	13
UNIT WILL NOT START	13
UNIT STARTS, BUT HAS DIFFICULTY DOING SO, AND DRAWS A HIGH CURRENT	14
VACUUM PROBLEMS	14
UNIT IS NOT DRAWING VACUUM	14
UNIT IS NOT REACHING ULTIMATE VACUUM LEVEL	14
OVERHEATING PROBLEMS	14
UNIT IS OVERHEATING	14
NOISE AND VIBRATION PROBLEMS	14
THE UNIT IS MAKING AN ABNORMAL NOISE OR SOUND	14



**THIS INSTALLATION, OPERATION, AND
MAINTENANCE MANUAL MUST STAY WITH
EQUIPMENT.**

**PLEASE REGISTER YOUR EQUIPMENT
WARRANTY AND START-UP RECORD ONLINE
AT WWW.DEKKERVACUUM.COM**

CUSTOMER SERVICE

Contact information



935 SOUTH WOODLAND AVENUE, MICHIGAN CITY, IN 46360-5672

TEL.: 219-861-0661 – FAX: 219-861-0662 – TOLL-FREE: 888-925-5444

Bus. Hours: 7:30 a.m. – 4:30 p.m. CST

Website: www.DEKKERvacuum.com

Order Information

When calling for service, parts or system information always have the pump or system model number and serial number(s) ready. Refer to the bill of lading or the gold-colored system information plate attached to the system (see image below).

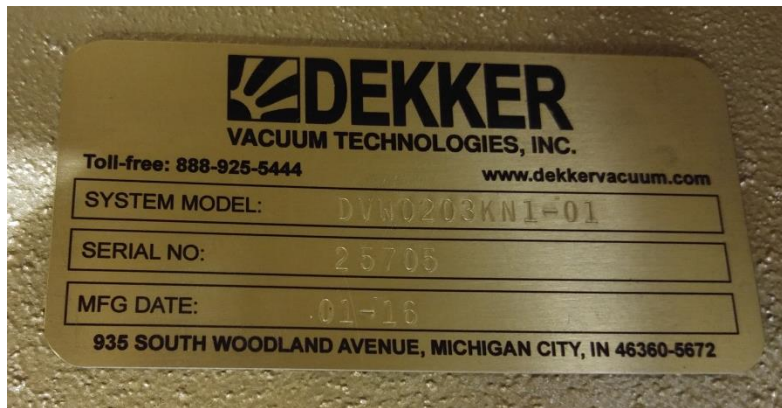

Gold-colored system information plate

Parts should be purchased from the nearest authorized DEKKER Vacuum Technologies, Inc. (hereafter referred to as DEKKER) representative (visit www.dekkervacuum.com to find a distributor near you via the [Distributor Locator](#)) or from the vacuum pump system supplier. If, for any reason parts, cannot be obtained in this manner, contact the factory directly.

INTRODUCTION

DuraVane^{HV} rotary vane vacuum pumps and systems has been designed to give you safe, reliable and trouble-free service, provided some of the basic maintenance guidelines as set out in this manual are followed. A vacuum pump is a rotating piece of equipment and operators must exercise good judgment and follow proper safety procedures to avoid damage to the equipment or personal injury. Please review and follow all instructions in this manual before attempting to install, start or operate equipment.

SAFETY

All vacuum pumps, systems and/or compressors (hereafter referred to as the Product) offered by DEKKER have been designed and manufactured for safe operation. However, the responsibility for safe operation rests with those who use and maintain these products. The safety department where the product is installed should establish a safety program based on OSHA, federal, state, and local codes. It is important that due consideration be given to hazards which arise from the presence of electrical power, hot liquids, harmful gases, and rotating equipment. Proper installation and care of protective devices is essential to safe system operation. These safety procedures are to be used in conjunction with the instructions contained in this manual.



**WARNING: DO NOT PUMP OXYGEN or oxygen rich mixtures with these pumps -
EXPLOSION HAZARDS!**

THEORY OF OPERATION

The DEKKER DuraVane^{HY} lubricated rotary vane pumps are single- or two-stage pumps with an integrated closed loop oil circulation system. All pumps are equipped with a gas ballast. Single-stage pumps have an external inlet check valve. Two-stage pumps have a relief device that puts the pump back at atmospheric pressure when rotation stops. Pumps are direct driven with a flange-mounted motor. Pump can operate with closed suction without overheating.

STORAGE

Keep the pump in a cool, dry environment and plug all open ports to keep out dirt and foreign objects.

INITIAL FREIGHT RECEIPT AND INSPECTION

Before a system ships from DEKKER, it is thoroughly tested, and will not be released unless it passes our Quality Control standards. All pumps are thoroughly inspected and are not released unless they pass our Quality Control standards. Once the product is received and signed for in Good Condition, DEKKER cannot be held accountable for undiscovered, unclaimed damage that is a result of freight transit. It is the responsibility of the receiver to thoroughly inspect and test the product for functionality upon delivery. The customer should take photos of the product as it arrives and send to DEKKER and the freight carrier if there are any issues. The party who selected the shipper is responsible for filing the freight claim. Failure to report these issues within the freight carriers' undiscovered damage window can result in non-acceptance of freight claims. DEKKER does keep photos of all systems, as shipped, to assist in freight claims. Report any damage immediately to the factory.

Key items to inspect:

- Is the product received as requested? Are all parts, accessories, and components delivered?
- Was the skid or crating received in good condition? Check for cosmetic damage.
- Check wiring inside of control panel. Are all wires should be terminated and connections tight? (If applicable)
- Check control panel components. Are they tight on DIN rail and/or other mounts/fasteners?
- Are there any leaks or puddles around the pump? Specify hose, piping or housing leak.

System must be given an initial startup test as soon as possible after delivery. This is to ensure that the motor has not shifted out of alignment during transit as well as to verify that electrical components are functioning without fault – Variable Frequency Drive (VFD), Programmable Logic Controllers (PLC), panel cooling fans, transducers.

INSTALLATION

Overview

The design of the piping, foundation layout, and plant location are the responsibility of the purchaser. DEKKER Vacuum Technologies, Inc. and its representatives may offer advice, but cannot assume responsibility for operation and installation design.

Please consult the factory or a specialist skilled in the design of plant layout, system piping design, and foundation design. The installer should carefully read this manual before installing the equipment. DEKKER or your authorized dealer can provide start up assistance in most instances for a fee. Contact DEKKER for hourly/daily service rates.

Unpacking

Upon receipt of unit, immediately inspect for signs of damage. Carefully remove packing or crating from around unit. Be sure to keep equipment in upright position.

Lifting

Lift the equipment carefully and with weight evenly distributed. DEKKER is not responsible for equipment that has been damaged through mishandling or dropping.

Location

Install the unit in a well ventilated and dust free area. The unit should be a minimum distance of 3 feet from surrounding walls to allow for checking fluid level, temperatures, pressures and general servicing.

Mounting

The unit must be installed on a level surface in the horizontal position. The foundation must be designed to support the total unit weight, without any settlement or crushing, be rigid and substantial enough to absorb any equipment vibration, maintain true alignment with any drive mechanism, and must permanently support the system baseplate at all points. The vacuum system must be leveled and secured with anchor bolts. Anchor bolts must be of adequate size to withstand the mechanical stresses exerted on it.

Systems 50 HP and larger should also be grouted into position per local codes. The foundation should be constructed to allow for $\frac{3}{4}$ to 1- $\frac{1}{2}$ inch of grout. The baseplate is set on shims and the grout is poured between the foundation and the baseplate. To have the required body to support the baseplate, grout should be at least $\frac{3}{4}$ inch thick.

The number and location of shims will be determined by the design of the baseplate. Firm support should be provided at points where weight will be concentrated and at the anchor bolt locations. Use enough, and large enough, shims to provide rigid support. Baseplates are usually designed with openings to allow pouring grout. When the baseplate has been shimmed, leveled, and the anchor bolts have been snugly tightened, a dam is constructed around the foundation to contain the grout. The dam level should be at least $\frac{1}{2}$ inch above the top surface of the shims. Grout should be poured inside and around the outside of the baseplate and leveled. Allow the grout to dry for a minimum of 48 hours before tightening the anchor bolts.

Please note that the pump/motor coupling and V-belt units will need to be realigned prior to start-up, with the exception of monoblock units.

Ventilation

Locate the unit in an area with sufficient airflow and accessibility. To prevent excessive ambient temperature rise it, is imperative to provide adequate ventilation. Cooling is an important aspect of reliable equipment operation and it is therefore important to install the unit in a reasonably cool area where the temperature does not exceed 104°F (40°C). For higher ambient temperatures contact the factory.

Typical system operating temperature is between 140°-185°F. Minimum oil temperature should not be below 45°F.

Electrical Preparation

All system wiring is performed at the factory if a control panel is supplied and installed on the skid. Check area classification to ensure all electrical enclosures comply with code. Required customer wiring is minimal, but should be done by a qualified electrician in compliance with OSHA, National Electric Code and any other applicable local electrical code concerning switches, fused disconnects, etc. DEKKER includes a wiring diagram in the control panel for use by the installer. DEKKER recommends a main disconnect switch be fitted between the vacuum system and the incoming power.

After the electrical wiring connections are completed, check the incoming voltage to make sure the incoming voltage is the same as the vacuum system voltage. Line voltage should be within the voltage tolerance as specified on the motor or to local code. Check the system for proper motor rotation. The direction of rotation is marked by an arrow on the motor or pump housing. Jog the motor by pressing the ON button and then the OFF button. If the rotation is incorrect, switch any two of the three main power leads (three phase power) on the contactor inside the control panel. Failure to do so could result in serious equipment damage.



WARNING: Install, ground, and maintain equipment in accordance with the National Electrical Code and all applicable federal, state and local codes.

Pipe Connection and Sizing

Before installation, remove all protective inserts on the pump suction and discharge. Piping connected to the system must be installed without imposing any strain on the unit components. Improperly installed piping can result in misalignment, general operating problems and pump failure. Use flexible connectors where necessary. Piping must be cleaned of debris before installation.

The piping system has to be designed to ensure that no liquids carried over from the process can reach the pump. If this possibility exists, a knock-out liquid separator should be installed. Consult the factory for recommendation.

Inlet Piping

Note: Install a temporary screen at the pump inlet flange at first start-up to protect the unit against carryover of pipe debris and welding slag. The screen must be removed after the initial run in period.

Inlet piping should be at least the size of the pump inlet. Install the unit as close as possible to the process to minimize losses due to the length of the suction line. If the unit has to be installed further away from the process, be sure the inlet piping is properly sized to minimize the overall line pressure drop. For more information consult the factory.

If the unit is operating in parallel on a common manifold must each have a manual or automatic shut-off valve and a suitable check valve installed in the suction line close to the pump suction flange. This allows each individual system to be isolated when it is not in operation. The line size of the manifold should be a minimum equal to the sum of the individual system pipe areas.







DEKKER recommends installing an inlet check valve. This valve is installed close to the pump suction flange to prevent back flow of process gas and seal fluid when the pump is stopped.

If the inlet gas pumped contains dust or foreign particles, a suitable 5 micron (or finer) inlet filter should be installed at the inlet port. For more information consult the factory.

Following are the inlet and discharge connection sizes for the different pump models:

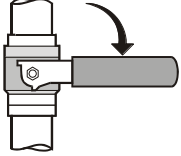
PUMP MODEL	INLET	DISCHARGE
RVL002H	3/8" HOSE	3/8" HOSE
RVL003H	3/8" HOSE	
RVL003W	1/4" G	
RVL006H	3/8" G	3/8" G
RVL010H	1/2" G	1/2" G
RVL013H	1/2" G	1/2" G
RVL014H	1/2" G	1/2" G
RVL020H	1/2" G	1/2" G
RVL020W	1/2" G	1/2" G
RVL030H	1" G	1 1/4" G
RVL030W	1" G	1 1/4" G
RVL031H	1 1/2" G	1 1/4" G
RVL031W	1 1/2" G	1 1/4" G
RVL050H	1 1/2" G	1 1/4" G
RVL050W	1 1/2" G	1 1/4" G
RVL051H	1 1/2" G	1 1/4" G
RVL051W	1 1/2" G	1 1/4" G
RVL070H	1 1/2" G	1 1/4" G
RVL070W	1 1/2" G	1 1/4" G
RVL075H	1 1/2" G	1 1/4" G
RVL075W	1 1/2" G	1 1/4" G
RVL076H	1 1/2" G	1 1/4" G
RVL076W	1 1/2" G	1 1/4" G
RVL110H	1 1/2" G	1 1/4" G
RVL111H	1 1/2" G	1 1/4" G
RVL125H	2" G	2" G
RVL145H	2" G	2" G
RVL145HH	2" NPT	2" NPT
RVL200H	2" G	2" G
RVL212HH	2" NPT	2" NPT
RVL215H	2" G	2" G
RVL300LH/HH	3" NPT	3" NPT
RVL301LH/HH	3" NPT	3" NPT
RVL400LH/HH	3" NPT	3" NPT
RVL401LH/HH	3" NPT	3" NPT
RVL475LH/HH	3" NPT	3" NPT
RVL550LH/HH	4" NPT	3" NPT
RVL700LH/HH	4" NPT	4" NPT

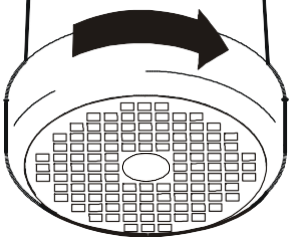
START-UP PROCEDURES

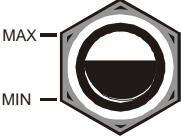
1	<p>Ensure all shipping plugs and/or paper covers are removed from system and tagging information is followed for successful startup.</p>	
	<p>The units do not contain oil when they ship from the factory. A container of oil is shipped with the unit. Before start-up add the supplied oil to the unit. Fill the unit to the middle of the sight glass before start-up.</p>	
	<p>Completely close the inlet suction valve before starting the unit.</p>	
3	<p>Jog the motor briefly and check direction of rotation. An arrow on the motor or pump housing marks the correct direction of rotation. If direction is incorrect, switch any two of the three leads at the power connection (three phase only).</p> <p style="text-align: center;"></p> <p style="text-align: center;">WARNING: OPERATING PUMP BACKWARD CAN CAUSE VANE FAILURE.</p>	
4	<p>Start and run the unit for approximately five (5) minutes, then stop.</p>	<p style="text-align: center;"></p> <p style="text-align: center;">DANGER: HIGH VOLTAGE! Lethal shock hazard present. USE EXTREME CAUTION!</p>
5	<p>With the unit shut off, check the oil level again. The oil level should be visible in the middle of the bulls-eye gauge. Add oil if necessary.</p> <p style="text-align: center;"></p> <p style="text-align: center;">WARNING: NEVER REMOVE THE OIL FILL PLUG WHILE THE VACUUM PUMP SYSTEM IS RUNNING.</p>	
6	<p>Start the unit and adjust the inlet suction valve to your desired vacuum setting. Check that the discharge pressure does not exceed 2 psig when operating deeper than 15" HgV. A pressure higher than 2 psig at start-up is a sign of high backpressure in the discharge pipe system. As the running time of the unit increases the backpressure will increase.</p>	

7	<p>Voltage and motor current should be checked by a qualified electrician and should be within the motor specifications.</p> <p>Note: This test should also be performed under normal system operating conditions.</p>	 <p>DANGER: HIGH VOLTAGE! Lethal shock hazard present. USE EXTREME CAUTION!</p>
---	---	---

SHUT DOWN PROCEDURES

To stop the vacuum pump, close suction valve and stop the pump. If oil is contaminated or emulsified the pump should be purged to clean the oil. Failure to do so will cause damage to the pump (for pump purging procedure see Maintenance section below)

MAINTENANCE



WARNING: Before attempting any maintenance such as changing the fluid, disconnect all power from the system by switching off the main breaker, isolate all energy sources and allow system to cool.

Pump Detail

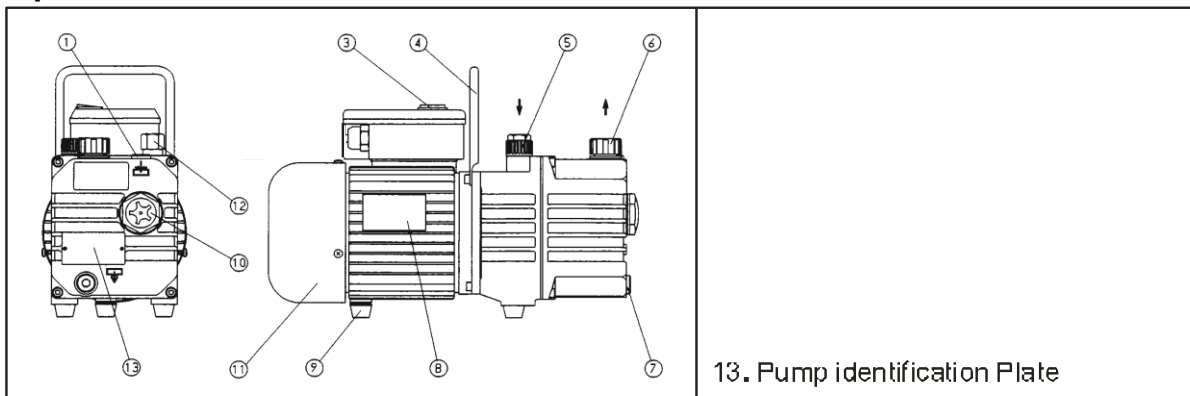

13. Pump identification Plate

Gas Ballast

To check and clean gas ballast, fully unscrew ballast and clean it thoroughly with compressed air. Change gasket if damaged.

Pump Oil Level (Check Daily)

Under normal circumstances it should not be necessary to add oil between recommended oil changes. A significant drop in oil level means there is an oil leak, a broken exhaust filter or a leaking anti-suck-back or inlet check valve.

It is normal for the oil to be slightly foamy and lightly colored. If the oil is milky or dark colored, it is burned or contaminated and must be changed.

Check the oil level only when the pump is shut off. The best time to check is before start-up. Replenish oil if the level drops below the MIN. line next to the sight glass. Oil must be added through the fill port only.

CAUTION: Do not add oil while pump is running, since hot oil can escape from the fill opening. Be careful when draining hot oil, personal injury could result.

MAINTENANCE SCHEDULE

To help ensure trouble free operation, a basic maintenance schedule consisting of the following system checks is recommended.

First 8 Hours of Operation

- Remove temporary inlet screen
- Check piping for signs of leakage and tighten if necessary

Daily

- Check oil level daily, sight glass should be half-full when pump is stopped.

500 Hours of Operation

- Under normal operating conditions, repeat Daily check procedure as described above.
- Standard oil should be changed every 6 months (or 500 hours of operation) or when oil darkens. Drain oil when warm, using caution, and properly dispose of oil.

1000 Hours of Operation

- Remove debris from pump housing, and motor fan guard.
- Synthetic oil should be changed every 6 months (or 1000 hours of operation) or when oil darkens. Drain oil when warm, using caution, and properly dispose of oil.

50,000 Hours of Operation

- Replace pump vanes.

TROUBLESHOOTING

The following is a basic troubleshooting guide and not all options may be included. Service should be done by a DEKKER authorized distributor or a properly trained service technician. Each unit is tested and checked at the factory. Always indicate model and serial number when calling. The model and serial number is viewable on the gold-colored information plate attached to the unit.



WARNING: Before attempting any maintenance such as changing the fluid, disconnect all power from the unit by switching off the main breaker, isolate all energy sources and allow unit to cool. All electrical work should be done by a qualified electrician in compliance with OSHA, National Electric Code and any other applicable local electrical code.

Start-Stop Problems

Unit will not start

1. Check if the disconnect or circuit breaker is switched on.
2. Check power. Make sure that supply voltage matches motor voltage.
3. Check power at source.
4. Check motor wires. Make sure connections are secure.
5. Check wire size and length. Incorrectly sized wires can cause a voltage drop at the motor.
6. Unit may be seized, contact the factory.

Unit starts, but has difficulty doing so, and draws a high current

1. Stop unit and disconnect power.
2. Check motor wires. Make sure connections are secure.
3. Check power supply. Excessively high or low voltage will damage motor.
4. Foreign particles may have carried over into pump causing damage to the vanes or other internal parts. Contact the factory.
5. Unit may have seized, contact the factory.

Vacuum Problems

Unit is not drawing vacuum

1. Stop unit and disconnect power.
2. Check vacuum gauge. Gauge may be faulty. Replace.
3. Check if the inlet valve is open.
4. Check process lines ensure that no lines are open to the atmosphere, causing loss of vacuum.
5. Check for leaks in piping systems, using conventional leak detection methods.
6. Internal parts may be worn or damaged. Contact the factory.
7. One or more of the vanes in the rotor may be stuck. Contact the factory.

Unit is not reaching ultimate vacuum level

1. Stop unit and disconnect power.
2. Check vacuum gauge. Gauge may be faulty. Replace.
3. Check to see if the process is holding vacuum. This can be done by shutting the unit down, isolate process from unit and observing for about 30 minutes if the gauge on the receiver or pipe system is holding. If vacuum is not holding, check all pipe connections for leaks using conventional leak detection methods.
4. Internal parts may be worn or damaged. Contact the factory.
5. Check pump model and specifications. Pump may not be suitable for application. Contact the factory.

Overheating Problems

Unit is overheating

1. Stop unit and disconnect power.
2. Make sure that pump is being cooled correctly. Check that pump is located in a well-ventilated area. Maximum ambient temperature for the rotary vane vacuum pumps is 104°F.
3. Inspect motor fan for damage.
4. Clean motor and pump air grills if needed.

Noise and Vibration Problems

The unit is making an abnormal noise or sound

1. Foreign particles may have carried over into the pump, causing damage to the vanes or other internal parts. Contact the factory.
2. Check bearings. If bearings are noisy, contact the factory.
3. One or more of the vanes in the rotor may be stuck. Contact the factory.